

Most evolved style

Most advanced CNC lathe, EGURO, oriented in linear turret lathe, developed with new viewpoints



NUCLET-10EL

■ Spindle headstock assuring high precision turning

Rigidity and accuracy oriented construction are basic points required for precision turning of 2nd operation. Based on its tradition and experience, EGURO designed the spindle headstock with the construction that the spindle is supported by double ultra precision angular contact bearings both at the front and the rear. This is good against the load from axial and radial direction and accordingly the accuracy of less than $0.5 \mu\text{m}$ is attainable for roundness and rigidity as well.

■ Linear turret tooling to minimize idling time

Eguro, linear turret oriented, has adopted linear turret to the tooling of NUCLET-10EX. Tools are fixed, without turret index, and minimizes idle time. This is good for accurate positioning and is essential for high precision turning of 2nd operation. Slide rapid traverse is $15\text{m}/\text{min}$, for both X and Z axes, by which high speed operation is achieved.

■ Stable positioning accuracy

Closed loop by optical scale of $1 \mu\text{m}$ resolution is standard specification for X axis, the slide of which is with carefully scraped grinding surface. Stable positioning accuracy is maintained from cold start.

■ NUCLET-10EXP for higher precision turning

Spindle built-in motor of 10,000 rotation per minute is mounted. Optical scales of $0.1 \mu\text{m}$ resolution are adopted for both X and Z axes. Together with standard model NUCLET-10EX, NUCLET-10EXP makes a line-up for customers' selection.

■ Good operationability

The style is soft and round, which is warm and friendly to the operators. Handle run, newly adopted, is a function to check program by the trace of the tools moved as per program by manual pulse generator, forward or backward direction. Interference or programmed moving of the tools can be checked before operation. CRT and operation panel are located at low position, in consideration of the operators' working condition. This upgrades the operationability.

Machine specifications

Item			NUCLET-10EX	NUCLET-10EXP	
Capacity	Swing over bed	mm	350		
	Swing over cross slide		200		
	Work size max.		φ80x60		
Spindle nose			Taper for collet	Flat φ100	
Collet	Max. dia.	mm	25.5	—	
Collet	Command		S4 digit	S5 digit	
	Speed	m i n ⁻¹	100~5,000	100~10,000	
Slide	Type of tooling		Linear turret		
	Tool size		mm □16		
	Control	X axis	mm	260	
		Z axis		250	
	Rapid traverse	X axis	m/m i n	15	
		Z axis		15	
	Control loop	X axis		1 μ closed loop	0.1 μ closed loop
		Z axis		—	1 μ closed loop
Jog feed rate		mm/m i n	0~1,260		
Number of tools		pcs.	per work to be turned		
Motor Spindle	Drive		Belt	Spindle built-in	
	Power	k w	FANUC α2 2.2/3.7	FANUC αB112 SS 2.2/5.5	
Motor	Coolant pump	k w	0.18		
	Lubrication pump		0.03		
Power	Electricity	k v A	9.7 (7.3kw)		
	Air	Mpa	0.4		
Machine height		mm	1580		
Center height		mm	1020		
Floor space (L x W)		mm	1,580x 1,360		
Machine weight		k g	1200		
CNC control unit		k g	FANUC System 21i-TA		

CNC control

Item	NUCLET-10EX	NUCLET-10EXP
Control unit	FANUC S. 21i-TA	
Axes controlled	2 (X, Z)	
Interpolation	Linear, Taper, Thread, Circular	
Program input	MDI, Tape	
Command	Incremental, Absolute	
Tape code	EIA/ISO	
Least input increment	X:0.001 (dia) Z:0.001	X:0.0001 (dia) Z:0.0001
Least command increment	X:0.0005 Z:0.001	X:0.00005 Z:0.0001
Max programable dimensions	±99999.999mm	±9999.9999mm
Feed radte	0.001~40.0000mm/rev.(1~5,000mm/min.)	
Thread cutting	0.0001~40.000mm	
Tool offset memory 16 pairs	±999.999mm	±999.9999mm
Dwell	0~99999.999 sec.	0~9999.9999 sec.
Backlash compensation	0~0.255mm	0~0.2550mm
Manual handle feed rate	0.01/0.001mm	0.01/0.001/0.0001mm
Tape memory	10m	
Auxiliary function	M2 digit , S 4 digit, T2 digit	
Canned cycle	O.D.(G90) Thread (G92) Face (G94)	
Reference point return	Manual, Auto. (G27, G28)	
Display	7.2 inch Liquid crystal	
Interface	RS232C	
Others: Standard	Handle run (Program retrace), Chamfer and Corner R Geometry offset, Work time and work piece display Constant surface speed control, Program number search, Sequence number search, Circular interpolation specifying arc R, Single block, Overtravel, Block delete Optional stop, Machine lock, Feed hold, Emergency stop	

Standard accessories

- Splash guard
- Cutting tool coolant
- Automatic lubricator
- Work light
- Collet blank
- Spindle nose cover
- Tool holder
- Tool holder base
- Tool holder base plate
- Hex key spanner
- Double ended spanner
- Driver
- Tool box
- Machine base
- Chip tank
- Machine lift up bolts

Optional specifications

- Air blower
- Oil mist coolant device
- Oil coolant through spindle device
- Pneumatic power chuck
- Hydraulic power chuck
- Precision pneumatic chuck
- Diaphragm chuck
- Auto. Door open/close
- Auto. Chuck open/close
- Barfeeder
- Bar pulling device
- Coolant oil
- Spindle clamping device
- Drill unit
- Milling unit
- Isanet function

Tooling area

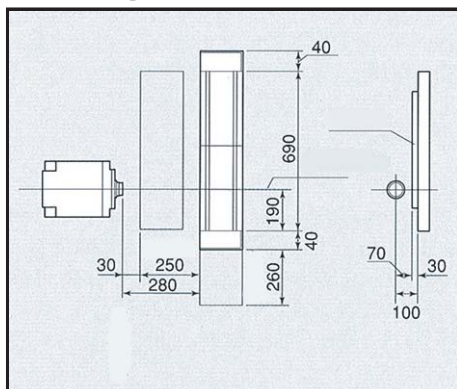

Dimensions

